

BOOK No. 100/AI. 2B

AIR PUBLICATION No. 2226. Vol. 1, Part 1.

**DRIVER'S  
HANDBOOK**

---

**MOTOR CYCLE, SOLO**  
350 c.c. o.h.v.

---

**ARIEL**  
**MODEL W/NG.**

THE LION PRESS (1931) LTD. WEST BROMWICH ED. 1.

## DATA SHEET.

### Engine Number.

Stamped on drive side crankcase, below cylinder base ; the letters preceding the number must be quoted with the number, e.g., BH.1234.

### Frame Number.

Stamped on saddle lug ; quote also the prefix letters, e.g., XG.12345.

### Gearbox Number.

Stamped on Gearbox end cover (outer) ; quote also the prefix letters, e.g., XICPBL.1234.

---

Petrol Tank Capacity	2½ galls.
Oil Tank Capacity	4 pts., 50 HD.
Primary Chaincase Capacity	app. ½ pt., 50 HD.
Gearbox Capacity	approx. 1½ pts. oil C.600.

## THE CONTROLS.

### Handlebar Controls.

- T. Twist Grip Control to the Throttle.** Controls engine speed. Rotate the top inwards towards the rider to increase engine speed. The full movement is approximately one quarter of a turn.
- B. Front Brake.** Hand lever in front of right hand. Pull towards handlebar to apply brake. Operates front brake only.
- A. Air Control.** Single lever near right-hand, controls additional supply of air to engine, enabling mixture of air and petrol to be varied according to conditions. Pull back towards the rider to open the air valve.
- C. Clutch Control.** Hand lever in front of left hand. Pull towards handlebar to declutch, *i.e.*, to disconnect drive from engine to rear wheel. When slowly released, enables drive to be restored to rear wheel gradually and without jerking. Always declutch to change gear.
- I. Ignition Control.** Advances or retards spark given by the magneto. Normal running position, except when starting, slow running or pulling hard is fully advanced.  
*On early machines with combined type controls the ignition lever is the lower of the two small levers near the left hand. Push forward to advance the spark.*

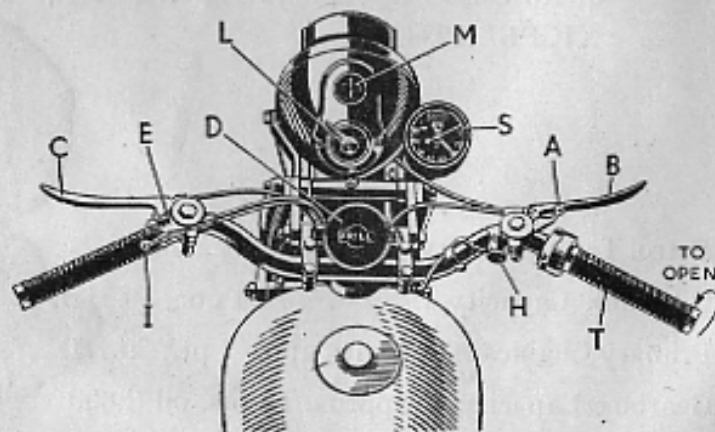

FIG. 1. THE CONTROLS.

*On later machines with separate controls the ignition lever is above the bar near the left hand. Pull back towards the rider to advance the spark.*

- E. Exhaust Valve Lifter Control.** Releases compression in combustion chamber, enabling engine to be rotated easily.  
*On early machines with combined type controls, the exhaust lifter is the upper of the two small levers near the left hand. Push forward to operate.*
- On later machines with separate controls, the exhaust lifter is the trigger lever below the left handlebar. Pull up to operate.*
- S. Speedometer.** Mounted on front forks. Registers the vehicle's speed and total mileage.
- H. Horn Switch.** Mounted on handlebar adjacent to right hand grip.
- Lighting Switch.** Situated below the saddle. Controls lighting of lamps by rotating the switch. Positions are marked on switch body. This switch also serves as a "Dynamo Tests Switch," for operation, see page 9.
- Main and Dim Switch**—in back of headlamp.

Pushing down and releasing switch changes the light from main to dim or vice versa.

*On earlier Machines.*

- L. The Lighting Switch** is situated in the headlamp and does not incorporate a "Dynamo Test Switch."
- M.** An **Ammeter** is mounted in the headlamp and indicates flow of current into (charge) or out of (discharge) battery.
- D.** A **Steering Damper** controlling the "stiffness" of the steering, is operated by a large milled

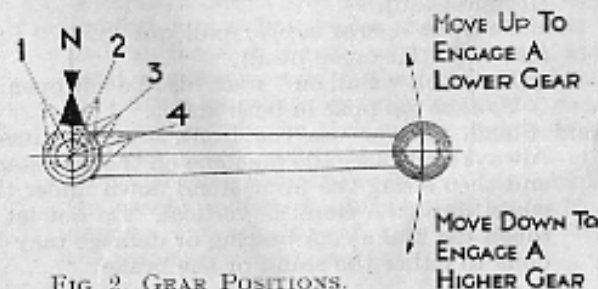

FIG. 2. GEAR POSITIONS.

knob in the centre of the handlebars. Turn clockwise to tighten. It is dangerous to use too much damping at low speeds as this makes the steering too stiff for the rider to have proper control.

### Foot Controls.

**Rear Brake Pedal** (*on left side*). Operates the rear brake only.

**Gear Control Lever** (*on right side*). Gear position is indicated by the small moveable pointer on the gear lever spindle. When this pointer faces the fixed pointer on the gearbox the gears are in neutral. The lever can be moved up and down through a small arc, and will return to the midway position on release.

**Foot Starter Lever** (*on right side, behind gear control lever*). For starting the engine. See "Instructions for Starting" on page 8.

### General Controls.

**Petrol Filler Cap.** To remove, slacken centre screw, rotate filler cap a quarter turn anti-clockwise, and lift up. To replace, drop into position, turn cap clockwise as far as possible and tighten centre screw.

**Petrol Tap.** A two-level petrol tap is provided. Always run on the main supply, then, when this is exhausted, the tap can be turned to the reserve position.

The reserve tap does not trap any definite quantity of petrol but will normally retain sufficient for at least 10 miles running.

Do not forget to close the reserve tap after filling up.

*To open main supply* pull out knob "Pull on." (Round head).

*To open reserve supply* pull out knob "Pull reserve." (Hexagon head).

The knob "Pull on" must also be left open.

*To close tap* push in both knobs.

**Front Stand.** Never use the front stand by itself. Always first place the machine on the rear stand and then swing the front stand down under the wheel until the stand is vertical. Do not let it touch the brake cam bearing or damage may be done to either the stand or the brake.

**Adjustable Footrests.** Each footrest assembly consists primarily of two parts:—

(a) The tubular supporting member with tapered end;

(b) The footrest, which can be swivelled round the tubular support.

Each assembly is carried on a stout rod which passes through holes in the rear engine plates. The tubular supports are prevented from rotating by locating pegs in each engine plate, whilst the footrests are locked on the tubular supports by the tapered joint, tension being applied by the nuts on the ends of the support rod which passes through the assembly.

If it is desired to swivel the footrest round the support tube to alter footrest position, the nut on the rod must be slacked when the taper joint can be broken by striking the footrest with a hammer, the direction of the blow being such as to rotate the footrest round the support tube.

Remember that the position of the foot gear control lever is also adjustable, and footrests and gear lever should be set in relation to one another to give a comfortable riding position combined with a "handy" position of the gear lever for easy gear changing.

**Shock Dampers (Fork).** Controlled by large hexagon nut, or hand controlled wing nut, on right hand end of the lower front fork spindle. Tightening the nut applies pressure to the spring star washer and increases the friction between the lower fork links and the fork girder, thus "damping" the fork action. For normal use on average roads very little damping is required and a free fork action will promote comfort and safety under these conditions. On bad surfaces, however, where the fork movement is excessive and violent, the application of a little damping, by screwing in the control nut, will steady the fork action and make the machine much easier to control. Never use more damping than the road conditions require. On machines fitted with the hand controlled damper nut adjustment may be made whilst the machine is being ridden.

## LUBRICATION SYSTEM.

SEE FIG. 3.

The engine is lubricated by oil 50HD, which is pumped from the oil tank situated just beneath the saddle on the right hand side and circulated to all bearing surfaces in the engine. The oil then falls by gravity to the base of the engine and is returned by the oil pump to the oil tank. The return side of the oil pump will return a greater quantity of oil from the engine than is delivered, so that under normal running conditions there will be practically no oil in the base of the engine. While the engine is stationary, oil from all parts of the interior drains down into the crankcase sump. Until this surplus oil is cleared, the return flow is very positive and continuous and can be observed running from the small spout just inside the oil tank filler neck. Under normal running conditions, this return flow is somewhat spasmodic and mixed with air bubbles.

In order to ensure that all oil in the engine sump can be returned to the oil tank as soon as the engine starts, do not fill the tank above the level of 1-in. below the return pipe spout. Do not allow the level to drop below about two-thirds full. The more oil there is in the tank, the cooler and cleaner it keeps.

There are two gauze filters in the Lubrication System. The one on the delivery side is situated in the oil tank and is accessible after draining, by unscrewing it from the back of the tank. When replacing, see that the suction oil pipe enters hole in end of gauze cylinder. The filter in the return side is situated in the engine sump and is accessible after removal of the under-shield and the four set bolts locked by wire.

The overhead valve gear is automatically lubricated by the oil pump. Report immediately if any defect is noted.

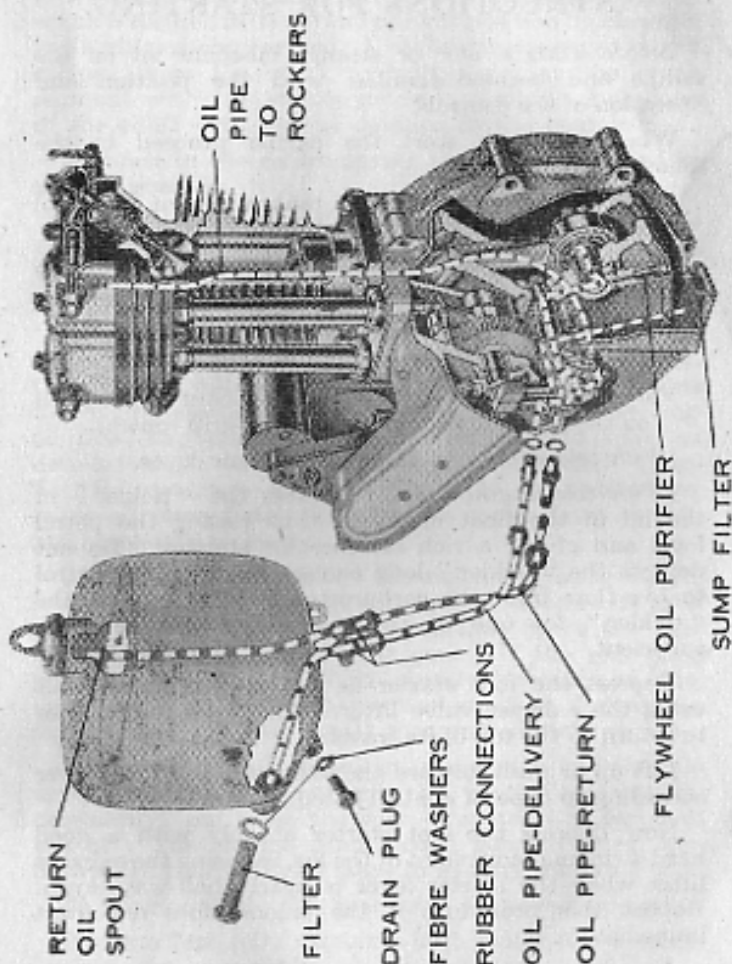

FIG. 3.

CUT AWAY VIEW SHOWING THE LUBRICATION SYSTEM.

## INSTRUCTIONS FOR STARTING.

Before using a new or strange machine, sit on the saddle and become familiar with the position and operation of the controls.

When ready to start the engine proceed in the following manner:—

Check for sufficient petrol in tank and turn on petrol supply at tap.

Check oil level in oil tank which should be up to 1-in. below the return oil spout (maximum level).

Check that gears are in the neutral position.

Set the ignition lever to one-third advanced.

Very slightly open the throttle—about one-eighth on the total movement of the twist grip control.

(With cold engine only). Close the air lever.

(With cold engine only). Depress the "tickler" in the lid of the float chamber, thus raising the petrol level and giving a rich mixture for starting. Do not depress the "tickler" long enough to cause the petrol to overflow from the carburettor. Holding down the "tickler" for one or two seconds should be quite sufficient.

Depress the foot starter as far as possible without using the exhaust valve lifter. Allow the foot starter to return to the top of its travel.

Lift up or push forward the exhaust valve lifter lever according to type of control fitted.

Now depress the foot starter sharply with a good hard-swinging movement of the leg, releasing the exhaust lifter when the starter lever is nearly half-way down. Repeat this procedure if the engine does not start immediately.

As soon as the engine starts, fully advance the ignition and open the air lever about half or three quarter.

NOTE.—To start the engine when hot proceed as described except (a) have the air lever about half open; (b) do not flood the carburettor.

**Warning.**—Make sure after use that the foot-starter crank is secured in its normal upright position by means of the spring catch provided. A broken or weakened return spring allows the crank to trail, engaging the crank segment with the starter ratchet, resulting in seizure of the shaft with serious damage to the gear box.

A defect in the return spring should be remedied as soon as possible.

When carrying a pillion passenger care must be taken to see that his leg does not come into contact with the crank in such a manner as to disengage it from its spring catch.

**Warming up.** Let the engine run at a fast tick-over for a minute or two if possible, before riding away. Open the air fully in about half a minute from the time the engine starts. Check oil circulation by removing oil filler cap and observing oil return into tank as detailed under heading "Lubrication System" (page 6). Do not race engine from cold. If ordered to move off immediately keep engine speed down and do not accelerate violently.

**On the road.** Sit astride the machine. Raise clutch lever to free clutch, wait for several seconds to give clutch time to stop spinning and then move the gear lever *upwards* to engage first gear. If the gear does not engage, maintain light upward pressure on the lever and move the machine backwards or forwards a few inches. The gear should then immediately engage.

To change up into second gear, declutch and throttle down (in order to prevent the engine revving unnecessarily) and press the gear lever *down* as far as it will go. The change from second gear to third, and from third gear to top, is made in exactly the same way.

To change down, the gear lever is moved *upwards*.

**Dynamo Test.**—On machines with switch below saddle only.

First insure tail lamp lights by putting switch to "Tail" position. Then put switch to "Test" position and slightly increase engine speed and observe if tail lamp lights. Lighting of the tail lamp may be taken as a sure indication that dynamo is charging normally. If tail lamp fails to light, report. After completing the "Test" return switch control to "Off" position.

### Hints on Driving.

Always start in bottom gear, changing up one gear at a time as the engine gathers speed. Always de-clutch to change gear, either up or down.

Keep the ignition fully advanced for all normal running. Retard only for starting, and occasionally slightly retard for hill climbing, or town traffic.

Don't hang on to too high a gear. Change to the next lower gear immediately the engine shows signs of labouring or if there is any snatch in the transmission.

Don't open the throttle suddenly when the engine is running slowly; this causes pinking.

Don't stand in gear with the clutch held out; place the gear in neutral.

Make all necessary adjustments periodically as indicated in the "Tasks."

### How to Change Gear Silently.

In order to give long life, the clutch is of large diameter and therefore possesses a fairly considerable amount of inertia. To obtain a good and silent gear change, a little care is required. When changing from a low to a higher gear, close the throttle and make a slight pause in the neutral position between the gears. The length of the pause will depend upon the engine revolutions but a little practice will soon indicate the proper length of pause.

When changing from a higher to a lower gear, leave the throttle partly open so that the engine speeds up as soon as the clutch is released, and then move the gear quickly, allowing the clutch to slip during the change. This speeds up the shaft and will give a silent change down.

To engage low gear when at a standstill, set the engine to tick over as slowly as possible, then release the clutch and hold it out for two or three seconds before endeavouring to engage the gear. This gives the plates time to stop spinning and it should then be easy to get into gear with practically no noise at all. Many riders rev. the engine excessively when engaging bottom gear. This is fatal to a quiet engagement.

### CHAIN ALTERATIONS AND REPAIRS.

When a chain wears or stretches so that it can no longer be kept at the correct tension by means of the chain tension adjustment, it must be examined to see if it is worn out or if it can safely be shortened. If the chain is damaged in several places or badly or unevenly stretched it should be replaced. In general, the enclosed primary chain should give good service for at least 20,000 miles; the rear chain, however, will probably not last more than 12,000 to 15,000 miles. If the chain requires shortening or a link replacing it is easily done with the chain rivet extractor and chain spare links carried in the tool kit.

#### Chain Rivet Extractor. (See Fig. 4).

The Pennant type of rivet extractor is illustrated in Fig. 4. To use, screw up the punch, press down the lever on the side plate to open the sliding jaws, place the chain roller between the jaws and release the lever so that the jaws close on to the roller and support the side plate. Screw down the punch until the rivet head is forced through the top or outer plate.

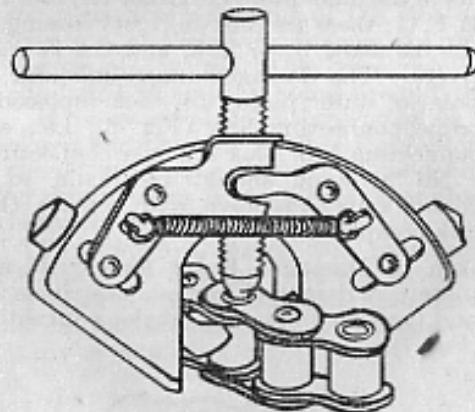

FIG. 4. PENNANT CHAIN RIVET EXTRACTOR.

#### Chain Alterations and Repairs. (See Fig. 4)

The illustration, Fig. 5, shows a short length of chain ending in a plain inner link at the left hand

end and a cranked link at the right hand end; the various parts are lettered for reference as under:—

- A. Roller.
- B. Inner plate.
- C. Outer plate.
- D, E, F, G, H, Rivets.

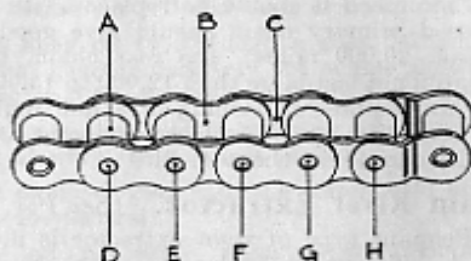

FIG. 5. LENGTH OF CHAIN WITH CRANKED LINK.

- (a) **Broken Roller or Damaged Inner Plate.** Should a roller A, or an inner plate B, become damaged, it is necessary to replace the inner link. To remove the inner link B, extract the four rivets D, E, F, G; these are the two rivets passing through the damaged inner link, and the two adjacent rivets. The damaged inner link and the two pairs of outer plates are then replaced by the triple connecting link (Fig. 6), i.e., a double connecting link plus a single connecting link. No attempt should be made to replace rollers only; remove and replace the inner link complete.

- (b) **Broken or Damaged Outer Plate.** If an outer plate C is damaged, remove the rivets F and G and replace with a single connecting link (Fig. 7).



FIG. 6. TRIPLE CONNECTING LINK.

- (c) **To shorten a Chain having a Cranked Link at one end.** Remove the rivet H (securing the cranked link), take out the cranked link and join the ends of the chain with a single connecting link (Fig. 7).
- (d) **To shorten a Chain not containing a Cranked Link.** Extract the third and fourth rivets (F and G) counting from the joint (left hand end of chain in Fig. 5) and join up the chain by using the double cranked link (Fig. 8) and single connecting link (Fig. 7).



FIG. 7. SINGLE CONNECTING LINK.

- (e) **Fitting Spring Clips.** Care should be taken when fitting spring clips not to strain them unduly; they must be slid into position and no attempt made to spring them over the tops of the rivets. When connecting up, put the loose outer plate in position (never try to run a chain without it), place the large end of the slot in the clip over one of the rivets, engage the points with the groove in the other rivet and slide the clip until it springs home around the rivet.

It is essential to fit spring clips with the closed end pointing in the direction of motion; should any fouling occur the tendency then is to retain them in position rather than to dislodge them.

To remove a spring clip, press against the points with a coin or screwdriver.

When a clip is removed after having been in use for some time, it is advisable to replace it by a new one.



FIG. 8. DOUBLE CRANKED LINK.



## PERIODICAL ATTENTIONS.

### DAILY.

**Oil Tank.** Check oil level and top up if necessary with oil 50 HD.

**Petrol Tank.** Check level and fill up if necessary.

**Tyres.** Examine for correct inflation. Do not rely on observation only. If in doubt, check with gauge, and inflate to correct recommended pressure.

### EVERY 1,000 MILES.

**Wheel Hubs.** A nipple is fitted in the centre of each hub, between the spokes.

Do not over-lubricate or grease will get on to the linings and render the brakes useless. Two or three depressions of the grease gun plunger should be ample.

**Steering Head Bearings.** Two or three depressions of the grease gun plunger on each of the two grease nipples is sufficient. Over-lubrication will cause grease to get on to the steering damper on machines on which the damper is fitted.

### EVERY 2,000 MILES.

**Engine Oil.** Drain tank and sump when oil is warm, i.e., after a run. Clean the two gauze filters in petrol. Refill with new oil.

On new and reconditioned engines, this operation should be carried out after the first 250 miles and again after a further 1000 miles.

**Contact Breaker Cam.** Lubricate as directed on page 35.

**Dynamo Armature Bush.** Lubricate oiler A (Fig. 12) as explained on page 37.

**Speedometer Gearbox.** Two or three depressions of the grease gun plunger should be adequate.

**Brake Cam Spindle Bearing.** The bearing must be greased at the period indicated. Remove the wheel under supervision, take off brake plate, take out cam spindle and grease spindle and bearing.

Notes on Wheel Removal are on p. 33.

### EVERY 5,000 MILES.

**Gearbox Lubricant.** With new machines, it may be found on removal of the filler cap, that the gearbox is filled with a light grease. On no account

must grease No. 2 be used to refill. Top up with oil C.600. The normal use of the machine will, in time, cause the mixture to become sufficiently fluid to be drained away, when the gearbox should be refilled with oil C.600. Top up, or refill, to within 2½ ins. of the level of the filler plug. Do not overfill or oil will be forced out through the mainshaft bearings.

On new boxes (if filled with oil and draining is therefore possible) and on reconditioned boxes this operation should be carried out after the first 500 miles running.

**Magdno Chain.** Remove chain cover under supervision and inspect the chain for broken rollers and tension. The chain should have approximately ¼-in. up and down movement in the middle, when at the tightest point. If any adjustment is necessary, or if the chain has any broken rollers, or is damaged at all, necessary rectifications must be made by Workshops.

On new and reconditioned engines this operation should be carried out after the first 500 miles.

**Flywheel Oil Purifier.** This is situated in the timing side flywheel and should be cleaned out by Workshops. Access is via the sump filter plate (after removing undershield) or via the crankcase mouth (after removing cylinder).

**Note.**—This attention is only required on machines up to Eng. No. 20,310.

**Carburettor (See Fig. 13).** The throttle taper needle and the needle jet are to be renewed every 5,000 miles.

### NEW MACHINES.

**Engine Oil.** Change at 250 and 1250 miles as directed on page 14 (para. headed "Every 2000 miles").

**Gearbox Lubricant.** Change at 500 miles as directed on page 14 (para. headed "Every 5000 miles").

**Cylinder Head Bolts.** The cylinder head is held by four bolts, two of which are inside the rocker boxes. Inspect the head joint daily. If it shows any signs of oil leakage the head bolts must be tightened by Workshops. So long as the joint shows no signs of leakage do not touch the head bolts.

**Cylinder Base Nuts.** The cylinder barrel is secured to the crankcase by four studs, the four nuts of which should be tightened diagonally a little at a time by the driver after the first 100 and 500 miles. If leakage still occurs the paper washer probably needs renewal and the defect should be reported.

**Magdyno Chain.** Examine at 500 miles as directed above.

### MAINTENANCE BY THE TASK SYSTEM.

Where "Inspect and Tighten" appears it must be noted that it is not intended that nuts should be tested with a spanner every six days, but that the joint in question should be examined for signs of movement or leakage. Tighten only if either condition exists. Over tightening may cause serious damage through stripped threads or broken studs.

No attempt should be made to tighten nuts that are locked by cotter pins, wire, locking plates or tab washers, unless it is evident that tightening is necessary, in which event the locking device should be replaced by a new one.

### TASK No. 1.

#### Engine.

#### A. Inspect gas-tight joints and tighten if necessary.

##### 1. Cylinder head joints.

*Examine for leakage, which will be indicated by oiliness at the point where the two faces are bolted together. The cylinder head is held by 4 bolts, 2 of which are inside the rocker boxes. Report if joint leaks, so that the joint may be re-made by Workshops.*

##### 2. Cylinder holding-down bolts.

*Examine for oil leakage. There are 4 nuts to be checked. If leakage still occurs after bolts have been evenly tightened, the paper cylinder base washer may need renewal. In this case report.*

##### 3. Carburetter.

*Carburetter flange bolts directly to head. Test for movement, examine for leakage, and check 2 securing nuts. Serious overtightening will distort the flange and cause leakage.*

##### 4. Exhaust pipe.

*Test for movement and examine for leaks which will be denoted by oil or soot deposit. Check nut on clamping ring holding pipe to head.*

#### B. Inspect engine mounting and tighten if necessary.

##### 1. Engine plate bolts.

*1 bolt at top of front plates and 2 bolts securing rear plates to seat pillar tube.*

##### 2. All crankcase bolts and timing case screws.

*8 bolts holding together the two halves of the crankcase (5 of these bolts also pass through the engine plates).*

*4 timing case screws.*

*7 magneto chain case screws (with aluminium cover), or*

*5 magneto chain case screws } with steel cover.  
2 " " " nuts*

##### 3. All brackets mounted on engine.

*One only—holding magneto platform to magneto chain cover—check small set bolt.*

## TASK No. 1.—Contd.

### C. Start engine.

#### 1. Listen for knocks.

*Report any knocks to workshop.*

#### 2. Uneven firing.

*Probably due to:—*

*Dirty or defective sparking plug.*

*Carburettor slow-running air adjusting screw requiring adjustment.*

*Tappet adjustment too close.*

*May be caused by the suppression resistor and/or immobiliser being badly or incorrectly fitted.*

#### 3. Examine exhaust smoke for correct mixture or excessive oil.

*Ignore slight blue smoke; this is oil burning.*

*Black smoke indicates too rich a mixture. Check carburettor for flooding and carburettor joints for tightness.*

### D. Switch off.

#### 1. Test for weak compression for—

(a) Valve trouble

(b) Piston trouble

(c) Gasket trouble

} Report any trouble  
found.

*If the engine is in good order, compression should carry the rider's full weight on the foot-starter lever for several seconds.*

#### E. Examine fins on cylinders for cracks or choked with dirt.

#### F. Report defects.

## TASK No. 2.

### Engine—Lubricating System and Fuel System.

#### A. Check oil level and refill where necessary.

*Maximum level:—One inch below the return pipe which is visible after removal of the filler cap.*

*Minimum level:—Two-thirds down the tank.*

#### B. Examine oil—if black, drain oil tank and clean both filters as detailed under Lubrication System, page 6.

#### C. Inspect oil-tight joints and tighten if necessary.

##### 1. Sump and crankcase plugs or drain-cocks.

*No crankcase plug or drain-cock—sump plate secured by 4 set bolts wired together; leave alone if wire is unbroken.*

*Tighten oil tank drain plug.*

##### 2. Oil pipe unions.

*2 pipes from oil tank to engine.*

*1 oil pipe to rocker boxes.*

*1 breather pipe from magneto chain case.*

*When tightening oil or petrol pipe connections, take care not to twist the pipe. Use two spanners, one on the union and one on the union nut. Before tightening the union, slacken off the union nut and do not overtighten or the fibre washer underneath the union will be damaged.*

##### 3. Valve gear cover plates.

*2 screw caps over rocker adjustment.*

#### D. Examine fuel system.

##### 1. Security of tank and carburettor.

*Tank held by 4 set bolts—each wired separately to tank bracket.*

*Leave alone if wire is unbroken and packing washers are tight. If leather packing washers are used they may compress in service thus loosening the tank. In this event carefully tighten bolts or insert new or additional packing.*

*Carburettor flange held by 2 studs and nuts. Do not overtighten or the flange will be distorted and cause bad running due to air leakage.*

*Task No. 2 continued on next page.*

## TASK No. 2.—Contd.

Check carburettor holding bolt; this is the hexagon bolt right at the bottom of the mixing chamber, below the float chamber arm.

### 2. Leaks—taps, unions, drain-cocks and tank.

See Petrol Tap is tight and check small grub screws holding-in tap plungers.

Test petrol pipe unions but take great care not to overtighten.

No drain cocks in fuel system.

### 3. Filters.

The filter is incorporated in the petrol tank and requires no attention as it is constantly cleaned by immersion in petrol.

### 4. Rubbing or kinked pipes.

### 5. Flooding.

Flooding may be caused by:—

Punctured float, bent needle, displaced needle clip (with bottom feed only), dirt on needle seating.

### 6. Air Cleaner.

Check for security; the cleaner is held on top of the tank by two side straps secured by nuts and bolts. Also check the three clips on the flexible pipe and elbow to carburettor. The cleaner should not often require dismantling for cleaning-out as vibration will shake dust and dirt out of the felt filter tubes.

If, however, there are symptoms of rich mixture, e.g., misfiring and black smoke from the exhaust, remove the cleaner by slackening the clamp clip at the top end of the flexible pipe and undo the two nuts on the side straps holding the cleaner to the tank. Remove cleaner and take off perforated base plate by springing back the four securing clips. Invert cleaner and tap gently to shake dust and dirt from felt tubes. See that spring clips holding ends of felt tubes to cleaner body are secure. Replace by reversing above procedure.

### E. Start engine—set control for slow running.

Drivers are not to alter jet settings or carburettor adjustments.

### F. Report defects.

## TASK No. 3.

### Ignition System. Sparking Plug. Charging System. Battery.

#### A. Magneto.

##### 1. Inspect, and tighten if necessary, magneto mounting.

Magneto secured by 3 set bolts screwing into base through platform.

##### Driving chain tension and lubrication.

The magneto driving chain is entirely enclosed and automatically lubricated from the engine. The driver should not remove the chain cover except under supervision.

##### Inspect contact breaker for correct operation.

Contact breaker point gap to be .012in. when fully open. The point opening can be observed (Fig 12) when the engine is turned, making sure the fibre peg is right on top of the cam. Failure to start the engine may be due to the points not opening or closing:

If the contacts need adjustment turn the engine round slowly by hand until the contacts are fully opened. Then slacken the locknut and rotate the contact screw by its hexagon head until the gap is set to the thickness of the gauge. Finally tighten the locknut.

Any adjustment to the contact breaker must be made under supervision.

##### 2. Inspect insulated wires for

- (a) Shorts and cracks, frayed or rubbed portions.
- (b) Contact with hot parts of the engine.
- (c) Faulty Connections.

Check that the high tension cable is securely fitted to the connector at the sparking plug end, to the pick-up at the magneto end, and to the suppressor and immobiliser.

To prevent interference with wireless communication, it is most important that the suppression resistor fitted to the high tension cable of all W.D. Motorcycles, is maintained in first-class condition. It must be clean, free from grease, and be securely connected at both ends. Loss of, or damage to, resistor or immobiliser must be reported for immediate replacement.

Drivers are not to alter ignition settings.

Task No. 3 continued on next page.

## TASK No. 3.—Contd.

### B. Sparking plug.

1. Check for leaks and tighten if necessary.
2. Inspect for cleanliness and cracked insulation.
3. Inspect and adjust gap to 15-thousandths of an inch for magneto ignition.

*It is occasionally necessary to dismantle the plug and thoroughly cleanse the inside. This is most easily done by holding the gland nut (small hexagon) in a vice and unscrewing the plug body (large hexagon). Take care not to grip the gland nut too tightly or it will be distorted and prevent the body unscrewing. If the insulation on the central electrode is mica do not scrape with anything sharp, such as a penknife, or the mica will be liable to flake off and cause pre-ignition. Use only a clean rag moistened with petrol. Clean the carbon from the inside of the body with an old penknife. When re-assembling, do not forget the copper washer (if fitted). Screw up tightly and re-set the points to the correct gap—.015in. to .018in.*

*Do not bend the central electrode. Adjust the gap by bending the electrode fixed to the plug body.*

### C. Dynamo.

1. Inspect and tighten if necessary:—mounting and assembly; cut-out mounting bolts and terminals. *Dynamo secured by strap over body, and screw at top of gear casing. Cut-out assembly is bolted to frame, under saddle.*

### D. Battery.

1. Clean battery vents. *To remove battery lid undo the bolt joining battery securing top strap to side strap.*
2. Clean, and smear lanoline (or, if unobtainable, vaseline) on terminals.
3. Inspect mounting and terminals and tighten if necessary.
4. Top-up with distilled water ( $\frac{1}{2}$  in. only over top of plates).

### E. Report defects.

## TASK No. 4.

### Steering. Brakes. Wheels. Tyres.

#### A. Examine controls.

1. Handlebars, fork links, front forks, springs, steering and shock dampers.

*Handlebars should be tight in mounting.*

*Fork links.—To check adjustment slacken off the fork damper nut, when the forks should move up and down quite freely, but without any trace of side play between the links.*

*To adjust the fork spindles, slacken the two hexagon locknuts—one at each end of the spindle—and rotate the spindles by means of a spanner placed on the squared end. Rotate the spindle anti-clockwise (viewed from the squared end) to tighten and clockwise to loosen.*

*Note carefully that re-tightening the locknut at the end of the spindle which is not squared will tighten up the adjustment. Therefore, adjust a little at a time, tighten locknut and test. When the final adjustment has been made, secure the locknut at the squared end.*

*The reason that tightening the locknut affects the adjustment is that the spindle at this end is stepped, the shoulder bearing up against the side of the link. When the locknut is loosened, the link may move away from the shoulder on the spindle causing extra clearance to develop.*

*For correct fork spindle adjustment, the knurled washers next the side links should just rotate easily.*

*After adjusting the forks re-tighten the damper nut. (See note below, "Shock dampers.")*

*Springs.—Examine fixing at each end. Check state of springs. In good order and with machine on rear stand, bottom fork links should point slightly upwards away from the steering head.*

*Shock dampers.—See that friction discs are not worn out. Adjust damper nut to apply the minimum tension necessary to prevent the forks bouncing on an average road surface.*

2. Brake pedal adjustment, fouling any part of machine.

*Rear brake.—Adjust by square-ended fulcrum screw in brake plate. Do not use thumb nut on*

### TASK No. 4.—Contd.

rod; this is only to be used to take up lost motion after the brake has been adjusted by means of the fulcrum screw.

#### 3. Hand brake lever, adjustment and wear.

Front brake.—Adjust by knurled nut on end of rod.

### B. Security.

#### 1. Mountings on handlebars, front forks, springs, links.

Check all control assemblies on handlebar. Speedometer mounting and link spindle nuts (7).

#### 2. Fixing of controls, pedals.

Pinch bolts through foot control lever and foot-starter lever. Brake pedal spindle nuts (2).

#### 3. Brake control adjustment, lock nuts.

Knurled nut on front brake rod. Wing nut and two spring locknuts on rear brake rod.

#### 4. Hub bearing lock nuts.

Leave undisturbed except when adjusting bearings.

#### 5. Wheel mounting nuts.

Keep dead tight.

#### 6. Brake cable and rods.

Bowden cable from front brake lever to brake rod.

### C. Lubrication.

#### 1. Links, spindles.

The four link spindles are lubricated (point 7) by five grease nipples—two in the fork bridges, two in the steering crown (one each side) and one in the ball head clip.

#### 2. Fork spring pivots.

Grease with gun the two pivot pins (point 11) at the lower ends of the fork side springs; oil with can the two points where the side spring top brackets pivot on the fork spindle.

#### 3. Examine for seized joints, brake rods and brake cam shafts.

Place one or two drops of oil from can on each of the following points: Face joint between front brake cam bearing and brake plate. Brake cam spindle bearing (front and rear) applied between cam lever and end of bearing. (Point 6—two).

### TASK No. 4.—Contd.

Swivel pin on end of front brake cam lever (Point 5). Swivel pin connecting rear brake rod to cam lever; also on screw threads on rod by wing nut (Point 5). Joint pin between front end of brake rod and brake pedal (Point 5). Grease with gun, nipple in brake pedal (Point 4).

#### 4. Ensure freedom of action of all return springs.

Return spring in tubular box at top of front brake rod.

Return spring round rear brake cam bearing.

### D. Wear and adjustment.

#### 1. Test for up and down play on steering head.

To check adjustment place box under engine, thus holding front wheel off ground, and slacken off the steering damper, when the whole fork assembly should rotate freely in the head bearings but without any trace of looseness. Also grip bottom end of fork girder and attempt to move backwards and forwards. Slackness may be in either the steering head bearings or in the fork spindles and bushes. Ascertain which by careful observation for movement.

To adjust steering head keep box under engine and slack pinch bolt through ball head clip; loosen top thin nut above clip and rotate lower thin nut. Tighten pinch bolt and top lock-out. Re-tighten steering damper just enough to take up slack.

#### 2. Test for rim rock in wheels.

When holding wheel rim and rocking sideways there should be a suspicion of slackness. If slight slackness cannot be felt, loosen adjustment. This is done by slackening the outer spindle nut E (Fig. 9) on side opposite brake drum; hold inner cone adjusting nut G and loosen outer locknut H. Adjust inner nut, and then still holding this inner nut, tighten the locknut and the outer spindle nut.

#### 3. Examine for worn brake linings and brake adjustment, worn or stripped threads.

If good brake operation cannot be secured by proper adjustment of the knurled nut (front wheel) or fulcrum adjusting screw and brake rod wing nut (rear wheel) the difficulty may

## TASK No. 4.—Contd.

be due to worn brake linings. Report for attention by Workshops.

### E. Wheel Alignment.

#### 1. Test alignment.

If the machine does not steer well or tyres show evidence of wheels running out of line, check alignment with straight edge or taut string which should touch both front and rear tyres at two points when checked on either side of machine.

If alignment is incorrect, it may be possible to rectify the fault by adjustment of the chain adjusters. See chain adjustment on page 30.

#### 2. Test wheels for signs of buckling or loose spokes. Do not attempt to tension spokes; this is a job for the workshop.

### F. Tyres.

1. Check pressure with gauge.
2. Examine for bad cuts, flints, nails, etc.
3. Examine for rotting, grease, oil, tar, and general wear of tread.
4. Examine tyre valves for missing caps and security.
5. Examine security bolts for tightness.
6. Examine for pronounced uneven tyre wear. This may indicate bent forks, or wheels out of line. Note.—See that any new tyres fitted have been recorded in A.B.412 with date, speedometer reading and serial numbers of old and new tyres.

### G. Report defects.

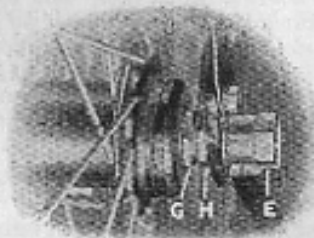

FIG. 9.

### WHEEL BEARING ADJUSTMENT.

(This illustration applies equally to front and rear wheels.)

## TASK No. 5.

### Transmission.

#### A. Examine controls.

1. Test for free movement of clutch lever, and that the clutch springs are returning the lever to normal after operation.

The top end of the clutch operating lever on the gearbox should have approx.  $3/16$  in. lost motion. This ensures that clutch springs are returning the lever to normal after operation.

2. Test operation of gear control lever.

Check with machine on stand and engine at rest. Move rear wheel by hand and see that gear control lever returns to normal position when released.

#### B. Lubrication—Gearbox.

1. Check oil level and top up if necessary.

Check oil level with dipstick inserted through filling orifice in top of gearbox, behind foot starter lever. Correct level is approximately  $2\frac{1}{2}$  ins. below filler orifice. Use oil C.600. The oil may be poured in through the filling orifice or it may be injected with a gun, through the grease nipple just in front of the filler (point 16).

2. Clean all external parts of box.

#### C. Security, lubrication and wear.

1. Examine primary chain cover for security.
2. Check primary chain for fouling, correct tension and correct lubrication.

Primary chain should have  $3/8$  in. up and down movement at tightest point. Test through inspection cap in case.

If chain is too tight or too slack, report for Workshop attention.

The chain is lubricated by dipping into the oil in the bottom of the chain case. To check oil level remove oil level plug below the foot-rest and see if oil flows out when machine is on rear stand. If oil does not overflow, remove chain inspection plug in top of case and slowly pour in engine oil until oil overflows through level plug hole. Allow any excess to drain out and replace inspection plug and oil level plug.

### TASK No. 5.—Contd.

#### 3. Examine Gearbox mounting.

Box held above, by clamp bolt through box and engine plates; below, by pivot bolt.

Check drain plug (if fitted) at bottom of box for security.

Check kickstarter crank securing nut, and lubricate spindle (Location No. 8.)

Check footchange for security and lubricate footchange (Location No. 9).

#### 4. Clutch for Drag and Lever Pin for Lubrication.

Clutch runs dry, in separate housing, outside chain case. "Drag" may be caused by oil on plates. If clutch appears oily report for Workshop attention.

With oil-can apply a little oil 50 H.D. to Clutch Lever Pin (Location No. 10).

#### 5. Test silence and easy selection of gears.

Noise and difficulty in changing gear is generally due to the clutch not disengaging properly. First check for excessive slack (lost motion) in the operating lever. The top of the lever on the gearbox end cover should have about  $3/16$  in. idle movement. Excess clearance may be due to the Bowden wire having stretched or to slight wear in the withdrawal mechanism. Stretch in the wire is compensated by the cable adjuster on top of the gearbox. The adjustment should

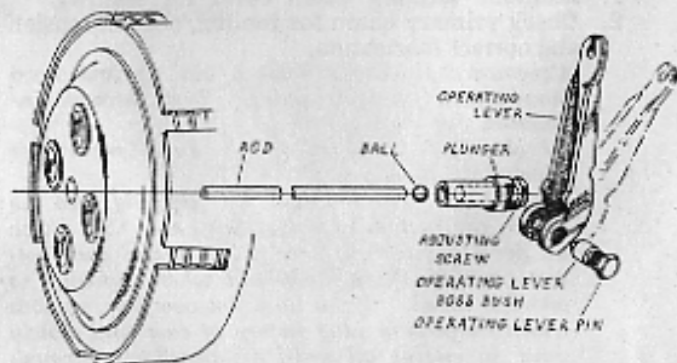

FIG. 10.  
CLUTCH WIRE ADJUSTMENT.

### TASK No. 5.—Contd.

be such that the wire is subjected to the minimum of bending when the clutch is withdrawn. Wear is taken up (Fig. 10) by screwing the adjusting screw into, or out of, the plunger. Push in the top end of the operating lever (thus withdrawing the clutch), and slip off the Bowden wire. Let the lever fall down and rotate the adjusting screw through the plunger, clockwise to decrease clearance and vice-versa. Replace the cable and check the idle movement. The adjustment cannot unscrew in operation as the head of the screw and flats formed on the plunger will only slide through, and not rotate in, the slotted operating lever.

To remove the rubber protecting cover, pull the top end down along the operating lever, after which the lever can be pushed in and the cable freed.

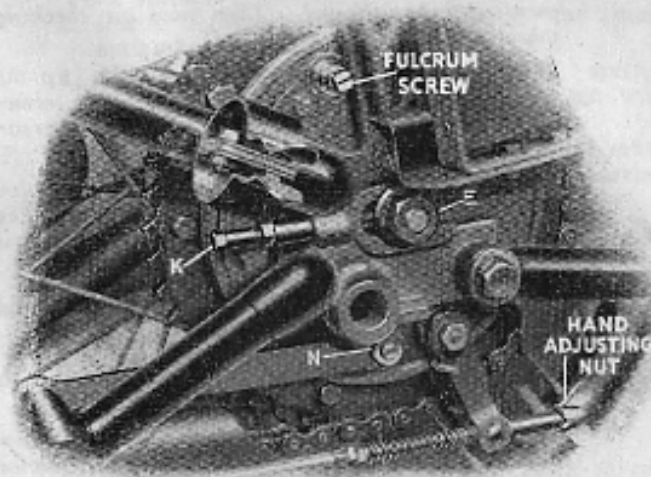

FIG. 11.  
REAR BRAKE FULCRUM AND CHAIN ADJUSTMENT.



## TASK No. 5.—Contd.

If the plunger is pulled out take care not to lose the ball which comes between the ends of the clutch rod and the adjusting screw.

If the above adjustment is not effective the trouble may be due to the spring plate not lifting evenly. Report.

6. Examine rear chain covers for security.
7. Check rear chain for fouling, correct tension, and correct lubrication.

Rear chain should have  $5/8$  in. up and down movement at tightest point midway between the sprockets. To adjust, slack off the two rear wheel spindle nuts E (Fig .11), and loosen the nut N securing the brake anchor bar to the brake plate. Adjust the chain by rotating the screw adjusters K after slackening the locking nuts. Be careful to turn each adjuster by an equal amount otherwise the wheel alignment will be affected. (See note on checking wheel alignment, Task 4. E.1).

After making the adjustment, tighten up the spindle nuts, the locknuts on the adjusting screws and the brake anchor bar nut. Adjust the rear brake if necessary.

Lubrication is through adjustable needle valve overflow from back of primary chaincase. The overflow only functions whilst the engine is running.

8. Examine chain sprockets for truth, alignment and wear.
9. If chains are very dirty or dry, remove to workshop for cleaning and lubrication.

When fitting chains the spring clip on the chain link must be fitted so that the open end follows the closed end when the chain is running. In the case of the rear chain fit the spring clip on the inner side of the chain, i.e., on the side nearest the spokes.

- D. Report defects.

## TASK No. 6.

### Frame and Fittings. Lamps. Horn, Etc. and General Items.

- A. Examine riveted, bolted, welded or brazed assembly joints for security.
- B. Examine for cracked members, especially :—
  1. Steering head lug and crown.
  2. Engine brackets.
  3. Front forks.
  4. Rear forks.
  5. Head lamp brackets.
- C. Examine frame for distortion. Report if the frame looks twisted, or the steering is difficult.

*Difficult steering may be due to the rear wheel not being in correct alignment with the front. Check this before concluding that the frame or forks are distorted. See Task 4. E.1.*
- D. Examine security of all bolted and riveted stays, brackets, hangers, etc.
- E. Fork springs.
  1. Check tightness of bolt securing the main spring top anchorage.
  2. Oil top pivots of fork auxiliary (side) springs with oil can and grease lower pivot pin with gun (Point 11).
- F. Examine general security and good order of mudguards, saddle, stands, tool boxes, battery carrier.
- G. Lamps and horn.
  1. Focus headlamp correctly.
  2. Check that lamp glasses are intact.
  3. Check the switches, lights, horn and other electrical devices.
  4. Note if lamps conform to black-out orders.
- H. General.
  1. Replace any missing lubricators and clear any clogged oilways.

*Refer to lubrication chart.*
  2. Lubricate any point which has been missed while carrying out the preceding Tasks.

*Refer to lubrication chart.*
  3. Clean tools, lightly smear with lubricant to prevent rusting. Check tools, and report deficiencies.

## ADDITIONAL NOTES ON MAINTENANCE.

In the following pages are given some additional notes on the proper maintenance of the motor cycle, together with more detailed explanations of the various adjustments which are required to be made in the six tasks. A number of illustrations are also included.

### Cold Starting.

For Temperatures below 16° F.

In climatic conditions where severe frost is normally experienced, starting will be difficult unless special precautions are taken. It is necessary under such conditions to drain the oil tank, engine, gearbox and primary chain case of all old oil and grease, and refill with lubricants suitable for low temperature operation.

In such cases information will be issued by the authorities.

After carrying out this work, the procedure for starting the engine is as follows:—

Free the engine by depressing the foot-starter several times before flooding the carburetter.

Proceed as detailed under the normal "Instructions for Starting" on page 8, but flood the carburetter fairly liberally. When the engine fires do not open the air immediately but place the closed fingers quickly two or three times across the air intake to give a temporary strangling effect. As soon as the engine begins to mis-fire and run irregularly, due to rich mixture, slowly open up the air until it is full open.

### Exhaust Valve Lifter.

This may require adjusting occasionally, in which case it should be set by altering the position of the exhaust lifter arm on the eccentric spindle. To break the taper joint between the arm and spindle, undo the nut half a turn and give the face of the nut a light sharp blow to drive the spindle inwards.

Leave the Bowden cable connected and turn the engine until both valves are closed. Operate the exhaust lifter lever on the handlebar until the top end of the lifter arm has moved forward approx.  $\frac{1}{2}$  in. from the normal "off" position. Now turn the lifter spindle clockwise—screwdriver slot in spindle end—until it makes contact with the rocker and retighten locknut. Always test the adjustment after re-setting the tappets and be sure that the lifter has slight idle movement before it touches the rocker, with valve closed.

### Front Wheel.

**Removal.**—Before removing the front wheel, place the machine on the rear stand and then lift up the front wheel and swing the stand round under the wheel. Let the stand swing just forward of the vertical position but take care not to let it touch the brake cam bearing or this may be damaged or the stand bent. Remove the bolt from the top end of the brake plate anchor bar, disconnect the speedometer cable at the lower end, slack the two spindle nuts and slip the washers out of the recesses in the fork ends, when the wheel will drop out.

### Rear Wheel.

**Removal.**—Place the machine on the rear stand; disconnect the brake rod from the brake cam lever by undoing the wing nut; disconnect the chain; remove the bolt through the front end of the brake anchor bar and frame lug. Slack the two rear stay nuts, also the two spindle nuts, then lift up the hinged portion of the mudguard and pull the wheel back out of the fork ends.

When replacing, reverse the procedure. Do not forget to replace the bolt through the anchor bar and see that the spindle nuts are done up securely.

The spring clip on the chain link must be fitted on the inner side of the chain and the open end of the clip must follow the closed end when the chain is running in the usual direction.

### Rear Brake Adjustment.

The rear brake is fitted with a fulcrum adjuster (Fig. 11) and all normal brake adjustment must be made by rotating the square-ended fulcrum screw situated in the brake plate diametrically opposite the brake lever bearing. Turn clockwise to compensate for wear. The hand adjuster on the rear end of the brake rod must be slacked off whilst the fulcrum adjustment is made. When the fulcrum spindle will turn no farther, re-tighten the hand adjusting nut until the brake pedal has only a trace of idle movement. Spin the wheel to make sure the brake is not rubbing. If the brake rubs, slack back the fulcrum adjustment one or two "notches." Always leave the adjustment so that the plungers (behind the brake plate) are in the notches. The position of the "notches" can be felt as the fulcrum spindle is rotated.

Always adjust the rear brake by means of the fulcrum adjuster or the best results will not be obtained. The thumb screw on the brake rod should only be used to compensate for rear chain adjustment.

## LUCAS LIGHTING AND IGNITION.

### Compensated Voltage Control.

The regulator causes the dynamo to give an output which varies according to the load on the battery and its state of charge. When the battery is discharged, the dynamo gives a high output so that the battery receives a quick recharge which brings it back to its normal state in the minimum possible time. On the other hand, if the battery is fully charged, the dynamo is arranged to give only a trickle charge which is sufficient to keep it in good condition without any possibility of causing damage to the battery by over-charging.

In addition to controlling the output of the dynamo according to the condition of the battery the regulator provides for an increase of output to balance the current taken by the lamps whenever they are switched on.

On machines fitted with an ammeter a discharge reading may be observed immediately after switching on the headlamp. This usually happens after a long run. In a few minutes the voltage will drop and the regulator will respond, causing the dynamo output to balance the lamp load.

### The Lamps.

To remove the headlamp front and reflector, press back the fixing clip at the bottom of the lamp and pull forward the *bottom* portion of the front. Some little force may be required. When replacing the front, locate the top of the rim first, then press on at the bottom and secure by means of the fixing clip. Make sure that the earthing clip makes good contact with the back of the reflector.

To remove the bulb holder, press back the two securing springs.

When fitting a main headlamp bulb, insert it with the "dipped" beam filament above the centre filament. When this filament burns out, turn the bulb round so that the second filament comes into use. The main bulb is 6v., 24/24w., spare part No. MT3/12534.

The tail-lamp bulb can be changed after removal of the rear portion of the lamp body. This is secured by a spring catch and simply requires rotating slightly and pulling straight back in order to release. To refit, push on with the "rib" on the body uppermost. The tail lamp bulb is 6v., 3w., spare part No. MT3/47174.

## THE MAGDYNO.

SEE FIG. 12.

To inspect the contact breaker, push aside the spring arm and lift off the cover.

Contact breaker springs B. and C. (Fig. 12) should be examined, and any rust wiped away.

The gap to which the contact breaker contacts E must be set when they are fully opened is about 12-thousandths of an inch; a gauge of this thickness is provided on the side of the spanner supplied with the magdyno. Adjustment of the gap and/or removal of the contact points should only be done by the driver under supervision.

If the contacts need adjustment turn the engine round slowly by hand until the contacts are fully opened. Then slacken the locknut and rotate the contact screw by its hexagon head until the gap is set to the thickness of the gauge. Finally tighten the locknut.

The cam is lubricated by a wick, which is contained in the contact breaker base. Add a few drops only of thin machine oil to the wick about every 2,000 miles. To render the wick accessible, remove the spring arm C (with backing spring B) carrying the moving contact and then withdraw the screw D carrying the wick. At the same time lightly smear with thin machine oil the tappet which operates the contact breaker spring. When replacing the arm see that the small backing spring B is fitted in its original position, *i.e.*, immediately after the securing screw and spring washer and with the bent portion facing outwards.

Next remove the pick-up or high tension terminal F. Wipe the moulding clean with a dry cloth. See that the carbon brush moves freely in its holder, being careful not to stretch the brush spring unduly. With the pick-up still removed, carefully clean the slip ring track and flanges by holding a soft cloth on the ring by means of a suitably shaped piece of wood while the engine is slowly turned round.

To render the contacts accessible for cleaning, remove the spring arm C carrying the moving contact by withdrawing the securing screw. When replacing the arm see that the small backing spring B is fitted in its original position, *i.e.*, immediately under the securing screw

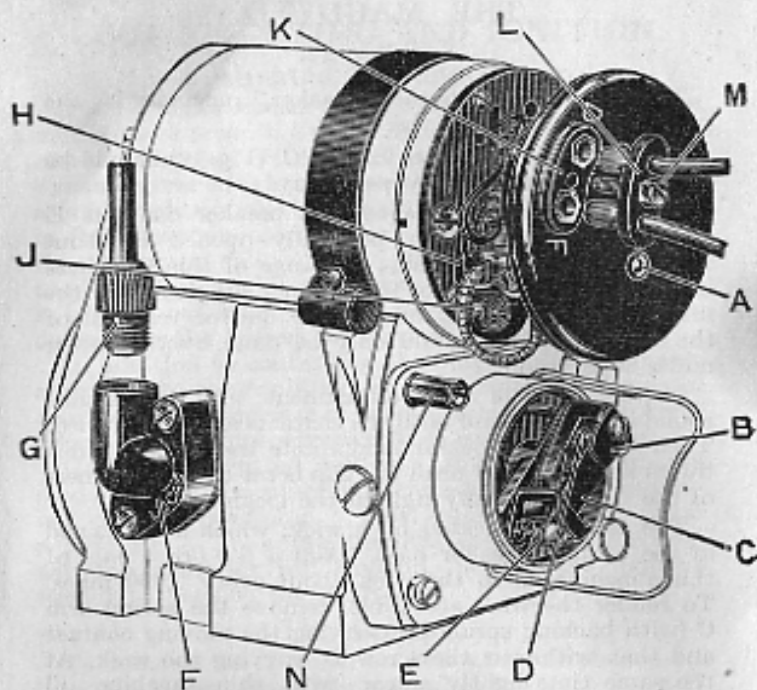

FIG. 12.

Magdynamo with Covers removed.

- |                                    |                                 |
|------------------------------------|---------------------------------|
| A. Lubricator.                     | G. H.T. Cable Fixing Nut.       |
| B. Contact Backing Spring.         | H. Dynamo Brush.                |
| C. Contact Spring.                 | J. Dynamo Brush Spring.         |
| D. Screw Holding Lubricating Wick. | K. Dynamo Terminals.            |
| E. Contact Points.                 | L. Terminal Fixing Plate.       |
| F. H.T. Pick Up.                   | M. Terminal Fixing Plate Screw. |
|                                    | N. Earthing Terminal.           |

and spring washer and with the bent portion facing outwards.

Dirty contacts may be cleaned by polishing with fine carborundum stone or fine emery cloth. Wipe away any dirt or metal dust with a cloth moistened with petrol.

The dynamo should not be touched except that the lubricator A, Fig. 12, should be given a few drops of oil from the can every 2,000 miles.

### THE CARBURETTER.

The standard carburetter setting is as follows:—

Main Jet ... ..	No. 120
Throttle Slide ... ..	No. 5/4

Taper Needle attached to throttle slide in the centre notch.

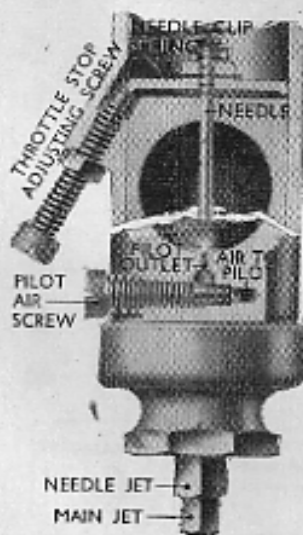

FIG. 13  
SECTIONED VIEW OF CARBURETTER  
MIXING CHAMBER.

(a) This illustration gives two diagrammatic sections of the carburetter to show:—

1. The throttle stop screw.
2. The pilot air screw.

Adjustment to either the Throttle Stop Screw or Pilot Air Screw should be done, if possible, only under supervision.

(b) Throttle Stop Screw. Set this screw to prop the throttle open sufficiently to keep the engine running when the twist grip is shut off.

(c) Pilot Air Screw. This screw regulates the strength of the mixture for "idling" and for the initial opening of the throttle. Turn the screw inwards to richen the mixture and outwards to weaken.

### LIST OF TOOLS IN TOOL KIT, Fig. 14.

1. Adjustable spanner.
2. Pliers.
3. Double-ended spanner for steering head and wheel bearing adjustment.
4. Double-ended spanner for wheel bearing adjustment and engine sprocket locknuts.
5. Double-ended spanner (fits 7/16in. and 1/2in. nuts).
6. Double-ended spanner (fits 5/16in. and 3/8in. nuts).
7. Double-ended spanner (fits 1/4in. and 5/16in. nuts).
8. Double-ended spanner (fits 3/16in. and 1/4in. nuts).
9. Ring spanner (fits 3/8in. and 7/16in. nuts).
10. Ring spanner (fits 1/4in. and 5/16in. nuts).
11. Tappet adjustment spanner.
12. Magneto spanner.
13. Tyre lever—cranked type.
14. Cylinder base nut spanner.
- \*15. Clutch spring adjusting nut spanner.
16. Grease gun.
17. Tyre lever—spoon type.
18. Tommy bar.
19. Screwdriver.
20. Box spanner for cylinder head bolts.
- \*21. Box spanner for clutch centre pins.
- \*22. Box spanner for flywheel oil purifier.
- \*23. Box spanner for clutch centre nut.
24. Box spanner for wheel spindle nuts.
25. Tool roll.
26. Oil can.
27. Tyre repair outfit.
28. Chain rivet extractor.
29. Front chain spare links.
30. Rear chain spare links.
31. Insulating tape.
32. Carrier strap.
33. Dynamo strap bolt spanner.
- 34.\* Tyre pressure gauge and schrader valve tool.

\* Not supplied with later machines.

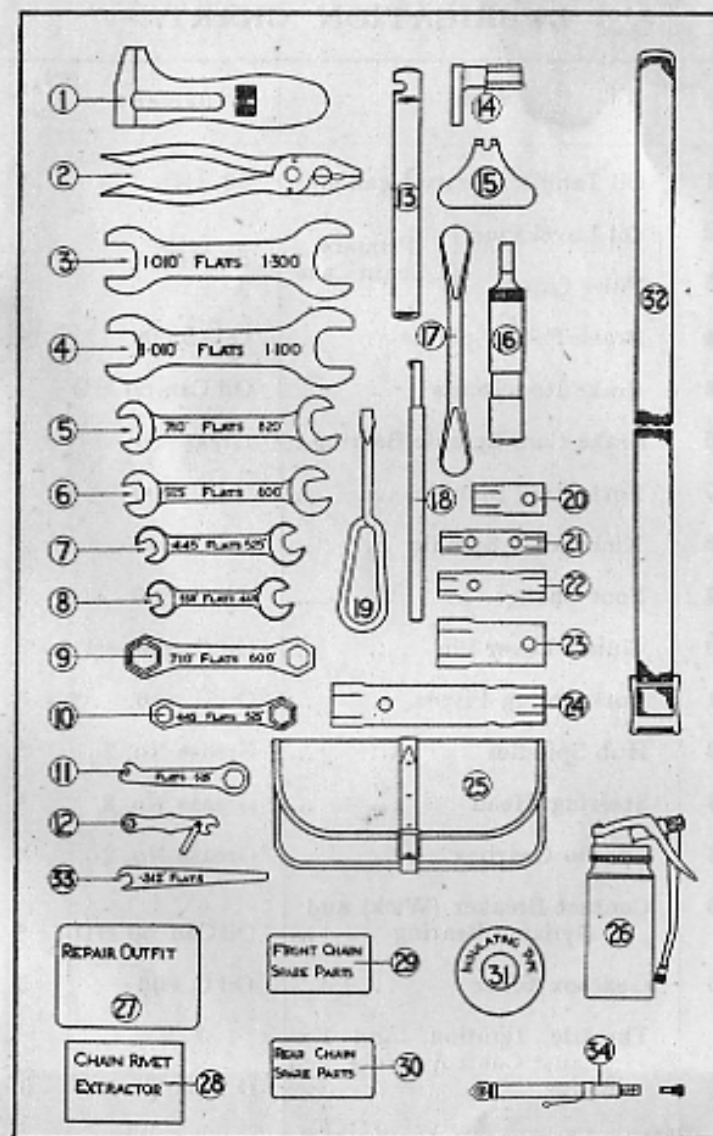

FIG. 14. THE TOOL KIT.

## LUBRICATION CHART.

NO.	PART	LUBRICANT	TASK NO.
1	Oil Tank (capacity $\frac{1}{2}$ gallon)..	50 HD	2
2	Oil Level Plug } Primary	50 HD	5
3	Filler Cap } Chain Case		
4	Brake Pedal Spindle ... ..	Oil C. 600	4
5	Brake Rod Joints ... ..	Oil Can 50 HD	4
6	Brake Cam Spindle Bearing...	Grease No. 3	*
7	Fork Link Spindles ... ..	Oil C. 600	4
8	Kickstarter Spindle ... ..	Oil C. 600	5
9	Foot Change ... ..	Oil C. 600	5
10	Clutch Lever Pin ... ..	Oil Can 50 HD	5
11	Fork Spring Pivots ... ..	Oil C. 600	4
12	Hub Spindles ... ..	Grease No. 2	*
13	Steering Head ... ..	Grease No. 2	*
14	Speedo Gearbox ... ..	Grease No. 2	*
15	Contact Breaker (Wick) and Dynamo Bearing ... ..	Oil Can 50 HD	*
16	Gearbox Filler ... ..	Oil C. 600	5
	Throttle, Ignition, and Ex- haust Control Joints and Pins ... ..	Oil Can 50 HD	6
	*Period Maintenance as ordered.		

T.L.C. 405 B.

LUBRICATION CHART.

